

WARNINGS AND CAUTIONS:

- TO AVOID FIRE, SHOCK, OR DEATH; TURN OFF POWER AT CIRCUIT BREAKER OR FUSE AND TEST THAT POWER IS OFF BEFORE WIRING!
- Risk of Electric Shock - More than one disconnect switch may be required to de-energize the equipment before servicing.
- To be installed and/or used in accordance with appropriate electrical codes and regulations.

WARNINGS AND CAUTIONS:

- If you are unsure about any part of these instructions, consult an electrician.
- Use this device with copper or copper clad wire only.

Mounting: For best RF performance and signal strength, do not mount this device inside a metal box. Final installed unit should also be mounted with open space on 2 or more sides.

INSTALLATION GUIDE

Part Number: CONTROL-485-101

DESCRIPTION

The Control-485 works in conjunction with other SimplySnap nodes to provide access to BACnet MSTP thermostats.

SPECIFICATIONS

Input power: 12-24VDC +/-10% or 24VAC +/- 10% from an UL listed Class 2, 24V transformer (not provided), half-wave compatible.

Dimensions: 7.8" L x 3.9" W x 2.8" H
 (200mm x 100mm x 70mm)

IP Rating: IP-62

Mounting: Independently surface mounted, Wall or I-Beam (mounting brackets included)

Control: Operating (Non-safety) HVAC/MAU control

Supported Thermostats: Honeywell BACnet FF TB3026

Serial Interface: RS-485 or RS-422

Baud Rates: 9600, 19200, 38400, 76800 and 115200

Radio: 2.4 GHz (IEEE 802.15.4), +20 dBm Transmit Power, -103 dBm Receive Sensitivity

Warranty: 1 Year

See www.synapsewireless.com/warranty for warranty terms.

CAUTION

- The Control-485 must be installed in accordance with national, state, and local electrical codes and requirements.
- All work must be performed by qualified personnel.
- The common signal from the Control-485 should not be tied to earth ground.
- Disconnect all power before installation or service.

NEEDED MATERIAL

- **Screw Driver:** A #2 Phillips is required to connect the cables to the terminals.
- **Mounting:** Mounting brackets are included. Mounting hole fits #10 screw
- **Conduit:** To maintain the IP rating of the unit, it must be installed with 1/2" cable glands or with weather-proof 1/2" conduit fittings at the power/signal entry points.

INSTALLATION INSTRUCTIONS

1. Select a suitable installation location for the Control-485 e.g. between the BACnet thermostat and the HVAC/MAU.
2. Select between inline or adjacent installation, see Figure 1 for more details.
3. Mount the Control-485 using the brackets included. (See last page of this install guide for mounting template).
4. Open the enclosure cover.
5. Install cable glands or conduit fitting as required.
6. For AC powered: Connect the AC power wires (e.g. from the HVAC 24VAC transformer) to wire terminals COMMON and 24VAC/DC maintaining the correct polarity. See Figure 2
7. For DC Powered: Connect the DC power supply wire (+) to 24VAC/VDC and (-) to COMMON. See Figure 3.
8. If the Control-485 is being connected inline with the BACnet thermostat, connect the thermostat power wires to the same Control-485 terminals COM/GND and 24VAC/DC. See Figure 2
9. RS-485/BACnet serial connections: Connect the Control-485 screw terminal D+ to MS/TP+ on the BACnet thermostat, D- to MS/TP- and GND to GND ;or connect to D+ to D+, D- to D- and GND to GND on any other RS-485 serially controlled devices. See Figure 4.

10. RS-422 serial connections: For serially controlled devices using the RS-422 standard, connect the Control-485 screw terminal RD- to the controlled device terminal TD-, RD+ to TD+, TD+ to RD+, TD- to RD- and GND to GND respectively. See Figure 5.
11. Ensure all control lines are reattached to the thermostat.
12. **Contact Synapse for Support-** (877) 982-7888

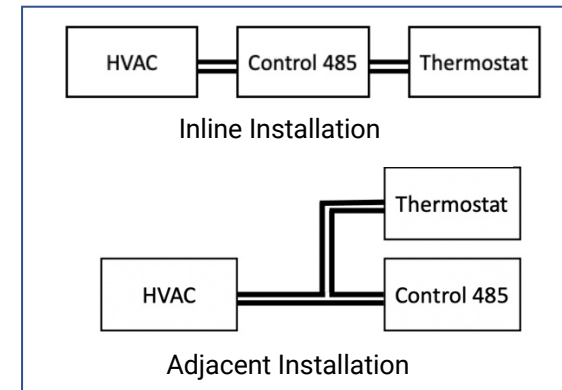

Figure 1. Installation options

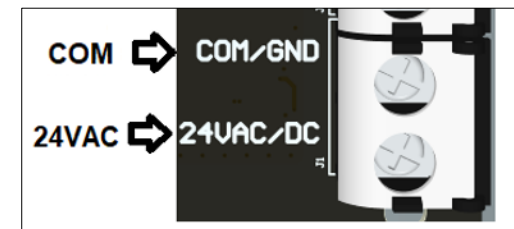

Figure 2. 24VAC connections



Figure 3. 24VDC connections

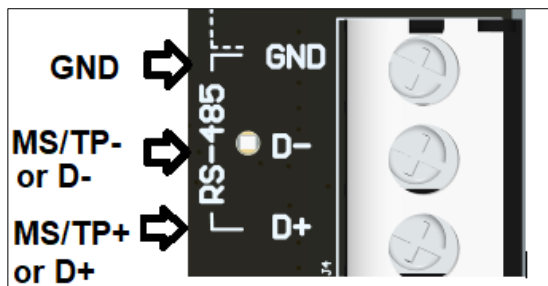

Figure 4. RS-485/BACnet connections

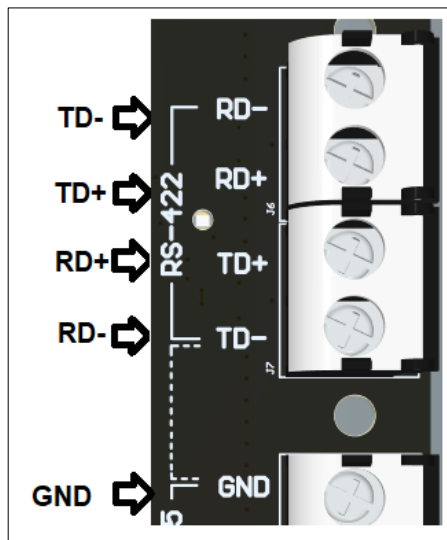

Figure 5. RS-422 connections

CERTIFICATIONS

Certifications: c(UL)us, FCC/IC, RoHS
IC: 7084A-SM220
FCC ID: U90-SM220
UL File Number: E513705
 Type 1 Action, Pollution Degree 2, Impulse Voltage 330V

RATINGS

Input Power: 12-24VDC or 24VAC, 50-60Hz
 Max Current Draw: 60 mA @ 24VAC
 Environment: 0C to +60C, 10 to 95% RH, non-condensing

REGULATORY INFORMATION AND CERTIFICATIONS

RF Exposure Statement: This equipment complies with FCC radiation exposure limits set forth for an uncontrolled environment. This equipment should be installed and operated with minimum distance of 20cm between the radiator and your body. This transmitter must not be co-located or operating in conjunction with any other antenna or transmitter.

Industry Canada (IC) certifications: This digital apparatus does not exceed the Class B limits for radio noise emissions from digital apparatus set out in the Radio Interference Regulations of the Canadian Department of Communications.

Le present appareil numerique n'émet pas de bruits radioélectriques dépassant les limites applicables aux appareils numériques de la class B prescrites dans le Reglement sur le brouillage radioélectrique edicte par le ministere des Communications du Canada.

FCC certifications and regulatory information (USA only)

FCC Part 15 Class B: This device complies with part 15 of the FCC rules. Operation is subject to the following two conditions: (1) These devices may not cause harmful interference, and (2) These devices must accept any interference received, including interference that may cause harmful operation.

RADIO FREQUENCY INTERFERENCE (RFI) (FCC 15.105): This equipment has been tested and found to comply with the limits for a Class B digital device, pursuant to Part 15 of the FCC rules. These limits are designed to provide reasonable protection against harmful interference in a residential installation. This equipment generates, uses, and can radiate radio frequency energy and, if not installed and used in accordance with the instructions, may cause harmful interference to radio communications. However, there is no guarantee that interference will not occur in a particular installation. If this equipment does cause harmful interference to radio or television reception,

which can be determined by turning the equipment off and on, the user is encouraged to try to correct the interference by one or more of the following measures: (1) Re-orient or relocate the receiving antenna; (2) Increase the separation between the equipment and the receiver; (3) Connect the equipment into an outlet on a circuit different from that to which the receiver is connected; (4) Consult the dealer or an experienced radio/TV technician for help.

Declaration of Conformity (FCC 96-208 & 95-19):

Synapse Wireless, Inc. declares that the product name "CONTROL-485-101" to which this declaration relates, meet the requirements specified by the Federal Communications Commission as detailed in the following specifications:

- Part 15, Subpart B, for Class B equipment
- FCC 96-208 as it applies to Class B personal computers and peripherals
- This product has been tested at an External Test Laboratory certified per FCC rules and has been found to meet the FCC, Part 15, Emission Limits. Documentation is on file and available from Synapse Wireless, Inc.

If the FCC ID for the module inside this product enclosure is not visible when installed inside another device, then the outside of the device into which this product is installed must also display a label referring to the enclosed module FCC ID. Modifications (FCC 15.21): Changes or modifications to this equipment not expressly approved by Synapse Wireless, Inc., may void the user's authority to operate this equipment.

CERTIFICATIONS

Model	: CONTROL-485-101
Contains FCC ID	: U90-SM220
Contains IC	: 7084A-SM220
UL File No	: E513705

Contact Synapse for Support- (877) 982-7888