

DIM10-087-06-A Controller

Load Ratings: 700mW @ 5 to 24V DC

Operating Temperature: -40 to +85 C / Operating Humidity: 10 to 90%, non-condensing



WARNING AND CAUTIONS:

- **TO AVOID FIRE, SHOCK, OR DEATH: TURN OFF POWER AT CIRCUIT BREAKER OR FUSE AND TEST THAT POWER IS OFF BEFORE INSTALLING!**
- **PROPER GROUNDING REQUIRED TO AVOID STATIC DISCHARGE WHICH CAN DAMAGE CONTROLLERS DURING INSTALLATION.**

WARNING AND CAUTIONS:

- If you are unsure about any part of these instructions, consult an electrician; all work should be performed by qualified personnel.
- Disconnect power at circuit breaker or fuse when servicing, installing or removing fixture or changing lamps.

INSTALLATION GUIDE

SPECIFICATIONS

- Dim Control Max Load: 10 mA Source/Sink
- Radio Frequency: 2.4 GHz (IEEE 802.15.4)
- RF Transmission Output Power: +20dBm
- Operating Temperature: -40 to +85 C
- Operating Humidity: 10 to 90%, non-condensing
- DALI-2: Limited to 6 LED Drivers
- Wire Size: 20 AWG, 7" Wires, 600V
- Dimensions: 3.05" L x 2.21" W x .47" H
(77.6 x 56.1 x 11.8 mm)

ANTENNA OPTIONS

Part #	Description
ANT-ORB-1.5-1	Outdoor Fixed Right Angle Antenna, 1.5 dBi gain
ANT-OSB-1.5-1	Outdoor Straight Antenna, 1.5 dBi gain
ANT-ORS-5.1	Stubby Antenna, Outdoor Right Angle
ANT-OSS-5.1	Stubby Antenna, Outdoor Straight

CAUTION

DIM10-087-06-A controllers must be installed in accordance with national, state, and local electrical codes and requirements.

DESIGN CONSIDERATIONS

Below are some recommendations for successful dimming using the DIM10-087-06-A. The dimming control wires are referenced as Dim+ and Dim-. The dimming signals have a Maximum voltage of 10V DC.

- Do not ground the DIM- wire to chassis ground; this is a return signal and is critical for proper dimming.
- Route dimming wires away from AC lines if possible.
- Maximum of 8 LED Drivers supported per controller.
- Do not mount to a heatsink or to a LED driver.
- When installing the DIM10-087-06-A into an enclosure, consideration of the external antenna position and interference is required in order to provide the most optimum wireless signal strength. Prior to permanently mounting it, make sure the antenna points directly upward or downward and is free of any metal objects within 12 in. of the antenna (Figure 1).

NEEDED MATERIALS

- **50 OHM Terminator plug RP-SMA:** Part Number 132360RP from Amphenol. (Used for temporary static protection of the antenna connector during installation and can be re-used)

INSTALLATION INSTRUCTIONS

WARNING: TO AVOID FIRE, SHOCK, OR DEATH: TURN OFF POWER AT CIRCUIT BREAKER OR FUSE AND VERIFY THAT POWER IS OFF BEFORE WIRING!

ATTACHING THE ANTENNA

1. Make sure the power is off. When handling the antenna cable, the technician must be grounded with a proper ground strap.
2. Remove red rubber dust cover, the washer, and nut from the antenna connector.
3. Attach the 50 OHM Terminator to the RP-SMA bulkhead hand tight.
4. Determine best location for external antenna position and create an opening to mount the antenna and bulkhead (See Figure 2 for measurements).
5. Remove the 50 OHM Terminator.
6. Feed the bulkhead through the opening in the fixture. (Note: Recommended max thickness of fixture wall is 6mm or 0.25 inches. This allows enough threads on the outside of the fixture for a good antenna connection.)
7. Place the washer and the nut back on the antenna connector and secure to fixture.
8. Screw on the antenna hand tight. Tighten a 1/4 turn with a pair of needle nose pliers. Do not over tighten or the RF pin in the bulkhead will crack, creating poor RF link quality.

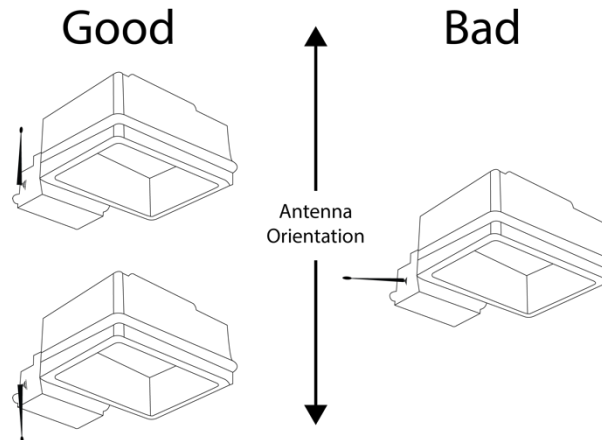

Figure 1 - Proper Antenna Installation

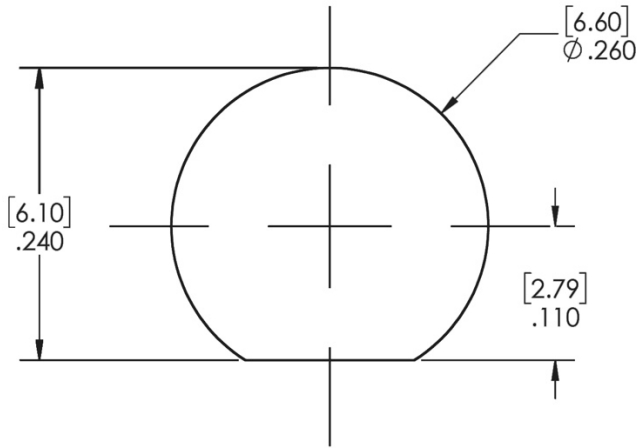

Figure 2 – Recommended mounting hole for 1/4-36UNS-2A threaded antenna with flat

MOUNTING

- Place the controller in desired location and secure it using #4 or M3 sized screws using the mounting holes located on the back edge of the DIM10-087-06-A.

WIRING THE DIM10-087-06-A CONTROLLER

Note: Unless specified, the connections to a standard Dim to Off LED driver and the DALI 2 LED driver are the same.

- Connect the 5-24V DC Aux output from the LED driver to the (POWER = RED) wire of the DIM10-087-06-A.
- Connect the (COMMON/DIM- = BLACK) wire of the DIM10-087-06-A to the COMMON/DALI- or COMMON/DIM- based on the LED driver you have.

CONNECTING SENSORS

Note: Steps 12-15 are for adding sensors to the DIM10-087-06-A controller; if you are not connecting sensors skip this section.

There are two sensor inputs on the DIM10-087-06-A designed for low powered (24V DC) type sensors.

- The (SENSOR A = BLUE) wire is used to connect sensor A.
 - The (SENSOR B = ORANGE) wire is used to connect sensor B.
- Connect the sensor power wire to the AUX out on the LED driver (the LED driver powers the sensor).
 - Connect the sensor Common to the COMMON/DALI- or COMMON/DIM- based on the LED driver you have.
 - Connect the sensor CTRL/Control wire to the (SENSOR A = BLUE) wire or the (SENSOR B = ORANGE) wire of the DIM10-87-06-A controller.
 - If you are using more than one sensor then duplicate the installation as described above.

(See Figures 3 AND 4)

CONNECTING THE DIMMING CIRCUIT

Note: Steps 16-18 are for connecting up to a Standard Dim to Off LED driver; if you are using a DALI 2 LED driver skip to steps 19-21.

- Connect the (DIM+ = PURPLE) wire from the DIM10-087-06-A to the DIM+ wire on the LED driver.
- Connect the (COMMON/DIM- = BLACK) wire from the DIM10-087-06-A to the DIM- wire on the LED driver.
- Cap unused (DALI- = BROWN) and (DALI+ = YELLOW) wires.
(See Figure 3)

Note: Steps 19-21 are for connecting up to a DALI 2 LED driver.

- Connect the DIM10-087-06-A (DALI- = BROWN) wire to the existing (Common/DIM- = BLACK) wire (connected in step 10) to the COMMON/DALI- wire on the LED driver.
- Connect the (DALI+ = YELLOW) wire from the DIM10-087-06-A to the LED driver DALI+.
- Cap the unused (DIM+ = PURPLE) wire.
(See Figure 4)

POWERING UP THE FIXTURE AND CONTROLLER

After connecting the Controller to the LED Driver and any sensors, make sure to cap any unused wires. Switch power on to the fixture. The light should turn on.

Note: When switched on, lamps should turn on to full brightness with approximately 10 V DC signal on the DIM+ wire using the DIM- wire as reference.

Refer to the SimplySNAP User's Manual for information on provisioning the DIM10-087-06-A.

REGULATORY INFORMATION AND CERTIFICATIONS

RF Exposure Statement: This equipment complies with FCC radiation exposure limits set forth for an uncontrolled environment. This equipment should be installed and operated with minimum distance of 20cm between the radiator and your body. This transmitter must not be co-located or operating in conjunction with any other antenna or transmitter.

Industry Canada (IC) certifications: This digital apparatus does not exceed the Class B limits for radio noise emissions from digital apparatus set out in the Radio Interference Regulations of the Canadian Department of Communications.

Le present appareil numerique n'emet pas de bruits radioelectriques depassant les limites applicables aux appareils numeriques de la class B prescrites dans le Reglement sur le brouillage radioelectrique edicte par le ministere des Communications du Canada.

FCC certifications and regulatory information (USA only)

FCC Part 15 Class B: This device complies with part 15 of the FCC rules. Operation is subject to the following two conditions: (1) These devices may not cause harmful interference, and (2) These devices must accept any interference received, including interference that may cause harmful operation.

RADIO FREQUENCY INTERFERENCE (RFI) (FCC 15.105): This equipment has been tested and found to comply with the limits for a Class B digital device, pursuant to Part 15 of the FCC rules. These limits are designed to provide reasonable protection against harmful interference in a residential installation. This equipment generates, uses, and can radiate radio frequency energy and, if not installed and used in accordance with the instructions, may cause harmful interference to radio communications. However, there is no guarantee that interference will not occur in a particular installation. If this equipment does cause harmful interference to radio or television reception, which can be determined by turning the equipment off and on, the user is encouraged to try to correct the interference by one or more of the following measures: (1) Re-orient or relocate the receiving antenna; (2) Increase the separation between the equipment and the receiver; (3) Connect the equipment into an outlet on a circuit different from that to which the receiver is connected; (4) Consult the dealer or an experienced radio/TV technician for help.

Declaration of Conformity (FCC 96-208 & 95-19):

Synapse Wireless, Inc. declares that the product name "DIM10-087-06-A" to which this declaration relates, meet the requirements specified by the Federal Communications Commission as detailed in the following specifications:

- Part 15, Subpart B, for Class B equipment
- FCC 96-208 as it applies to Class B personal computers and peripherals
- This product has been tested at an External Test Laboratory certified per FCC rules and has been found to meet the FCC, Part 15, Emission Limits. Documentation is on file and available from Synapse Wireless, Inc.

If the FCC ID for the module inside this product enclosure is not visible when installed inside another device, then the outside of the device into which this product is installed must also display a label referring to the enclosed module FCC ID. Modifications (FCC 15.21): Changes or modifications to this equipment not expressly approved by Synapse Wireless, Inc., may void the user's authority to operate this equipment.

CERTIFICATIONS

Model	: DIM10-087-06-A
Contains FCC ID	: U90-SM220
Contains IC	: 7084A-SM220
UL File No	: E346690

Contact Synapse for Support- (877) 982-7888