

Specification Data	
Job Name	
Type	
Catalog #	
Comments	

PRODUCT OVERVIEW

The **BMS Gateway** serves as the bridge between SimplySnap Intelligent Lighting Solution and Building Management Systems (BMS).

With the BMS Gateway, you can integrate the advanced lighting controls of SimplySnap with your current BMS solution. The integration makes it simpler to manage and maintain all of your facility's commercial or industrial automated applications through one system.

Combining smart lighting controls with existing BMS boosts energy savings by providing targeted and reliable power consumption data.

Like the BMS, SimplySnap is scalable, and can readily support future growth and expansion.

KEY FEATURES:

- Allows SimplySnap deployment to be controlled by standard BMS solutions
- Supports BACnet IP and BACnet MS/TP
- Supports Modbus TCP/IP and Modbus RTU (RS-232, RS-485)



Combining
the Power of
SimplySnap
with BMS
Solutions

Product #	Description
BMS-GW-002	BMS Gateway
Dimensions	4.0" H x 1.1" W x 2.7" D (102 mm H x 28 mm W x 68mm D)
Operating Environment	-20°C to +70°C; 10-95% relative humidity, non-condensing; indoor use only
Power Supply Options	Included external power supply rated for 0°C to +40°C; DIN Rail power recommended for temperatures outside that range.
Electrical Connections	<ul style="list-style-type: none"> • 3-pin Phoenix connector with: RS-485 (Tx+ / Rx- / gnd) • 3-pin Phoenix connector with: Power port (+ / - / Frame-gnd) • Ethernet 10/100 BaseT port
Input Power	12-24V DC, 0.3 A
Certifications	UL, RoHS, FCC, CE, BTL
Warranty*	2 Years

*See www.synapsewireless.com/warranty for warranty terms

To learn more, call or visit:
synapsewireless.com
(877) 982-7888

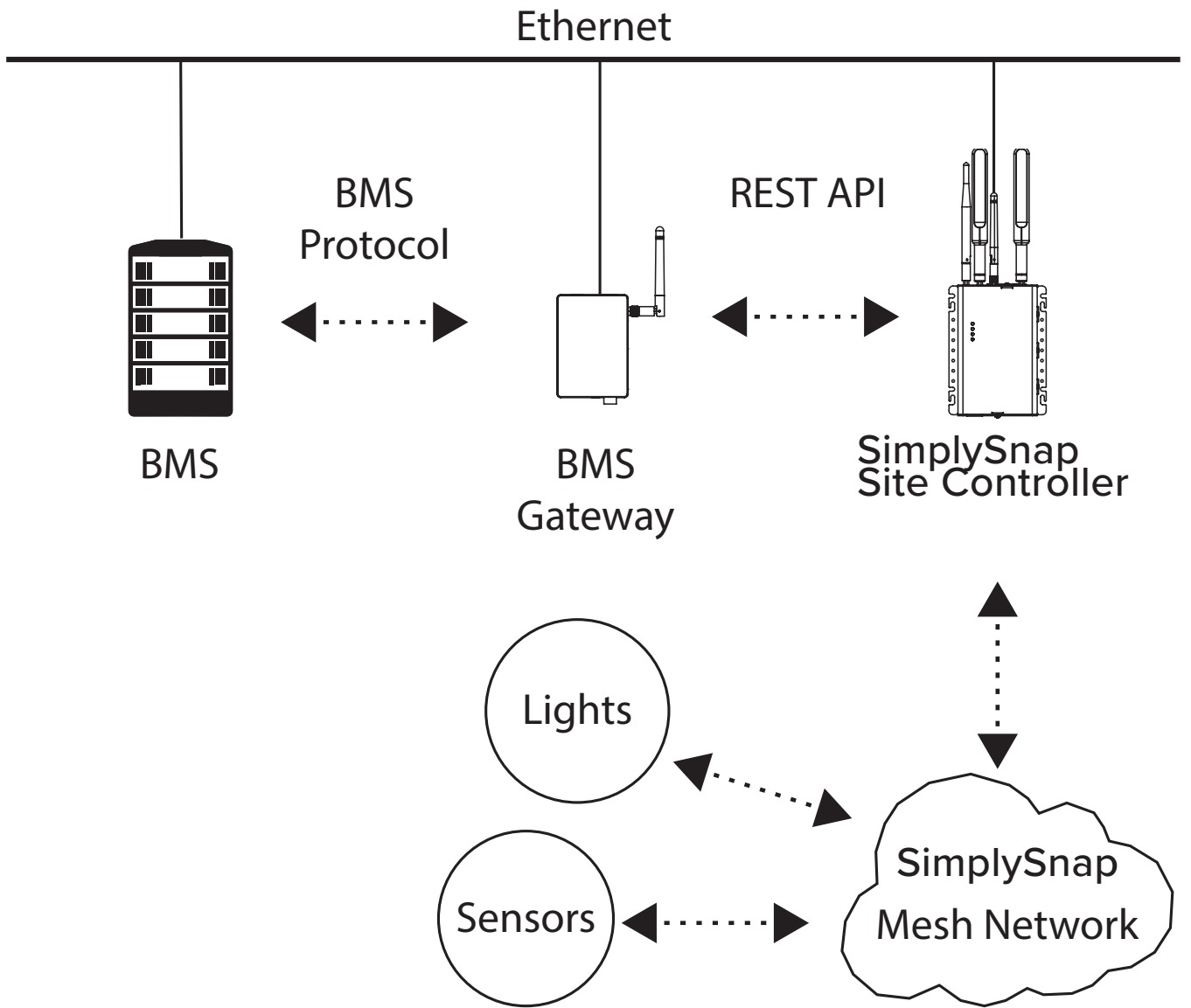

Example Setup of a BMS/SimplySnap Integration